

### SELF-PRIMING PUMP FEATURES

<b>Body:</b>	Bronze
<b>Impeller:</b>	Jabsco Neoprene Compound
<b>Shaft:</b>	316 Stainless Steel
<b>Shaft Seal:</b>	Lip Type
<b>Ports:</b>	3/4" NPT
<b>Weight:</b>	6 lb (approx.)

### APPLICATION

Marine Engine Cooling

### FOR ENGINE MODELS

CHRIS CRAFT - M Series (131 to 158 HP)  
 PALMER - DH 120  
 KERMATH - Sea Rover  
 LATHROP - LH Master-LH6-LH - Atom  
 OSCO - Hercules Diesel 685  
 UNIVERSAL - Super 6-Model Z  
 HERCULES - JX  
 (and others)

### INSTALLATION INSTRUCTIONS

Engage shaft with drive tang, make sure flange seats squarely on mounting surface and bolt to engine. Connect inlet and outlet fittings using pipe compound to seal threads.

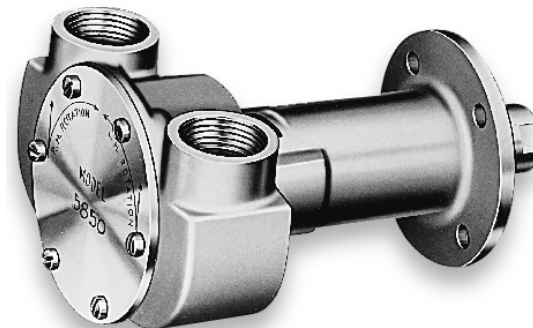

Model 5850-0001

### OPERATING INSTRUCTIONS

Pump will self-prime at low or high speeds. Make sure scoop and inlet line are clear and all connections airtight. Do not run pump dry for more than 30 seconds. Lack of water flow may damage impeller. To drain pump, loosen end cover screws.

### SERVICE INSTRUCTIONS

**IMPELLER REPLACEMENT:** Remove end cover and gasket. Pull impeller out by grasping hub or blades with pliers. Replace impeller, gasket and end cover. A light coating of grease in impeller bore will aid priming on dry start up. (Use correct Jabsco gasket, a thicker or thinner gasket may cause impeller damage.) Standard gasket is 0.010" thick.

### DIMENSIONAL DRAWING

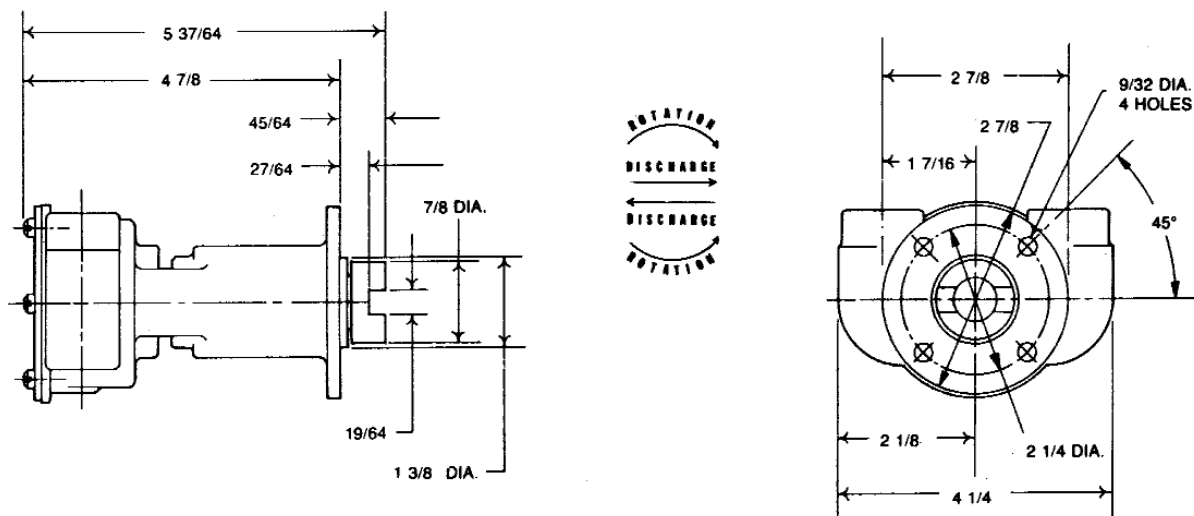

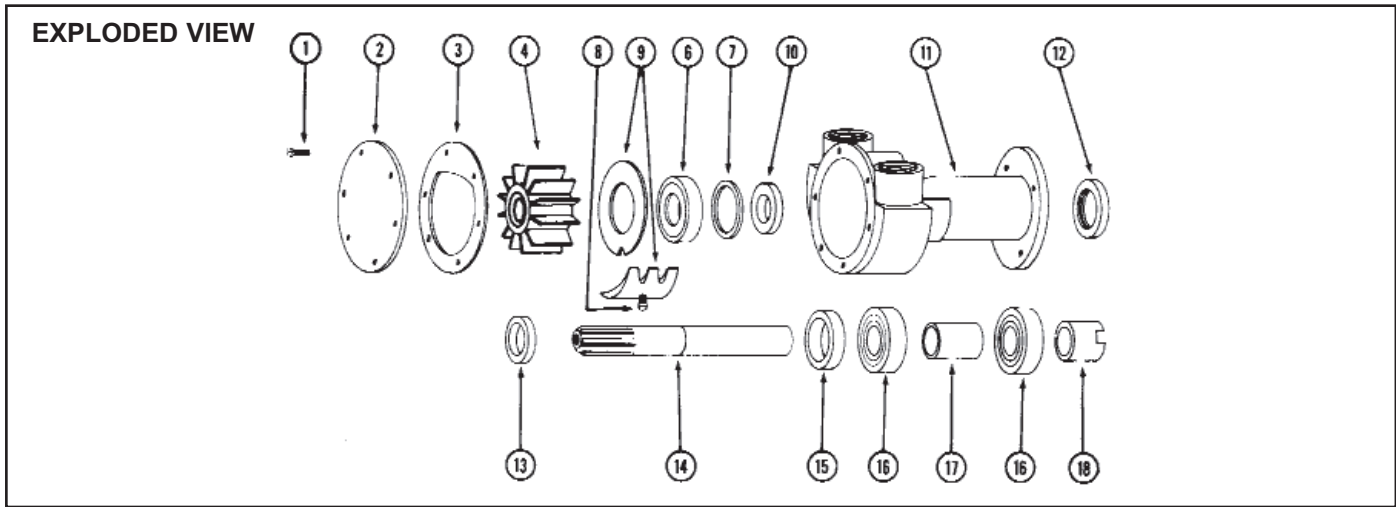

**MAJOR REPAIR:** Remove pump from engine to replace seal, bearings or shaft. To disassemble pump, remove end cover, gasket and impeller as outlined above. Press on impeller end of shaft to remove shaft and bearing assembly. Remove cam and wearplate assembly. Use screw driver to pry bearing seal out of bearing bore. Press shaft seal out towards impeller bore. Replace all worn parts. When installing coupling, support splined end of shaft. Press bearing seal in bearing bore with lip towards bearing. Press shaft and bearing assembly into bearing bore. Press adaptor ring into body. Install slinger on shaft. Install seal spacer in seal cavity. Install O-ring in seal bore. Press seal in seal cavity with lip facing toward impeller bore. Apply a thin coat of sealant to top of cam and cam screw threads, install wearplate and cam assembly. (Be sure cam is flush with end cover surface.) Secure with screw. Lubricate impeller bore, install impeller. Lubricate impeller face, install gasket and end cover and secure with screws.

**PARTS LIST**

Key	Description	Qty.	Part Number
1	Screw (End Cover)	6	91002-0020
2	End Cover	1	11830-0000
3*	Gasket	1	3298-0000
4*	Impeller	1	1210-0001
6*	Seal (Shaft)	1	92700-0060
7*	O-Ring †	1	92000-0210
8	Screw (Cam)	1	91003-0010
9	Cam Wearplate Assembly	1	7884-0000
10	Seal Spacer	1	3166-0000
11	Body	1	
12	Adaptor Ring	1	3376-0000
13	Slinger	1	3286-0000
14	Shaft	1	5857-0000
15	Bearing Seal	1	92700-0060
16	Ball Bearing	2	92600-0130
17	Bearing Spacer	1	3383-0000
18	Coupling	1	3278-0000
	Service Kit		90033-0001

\* Parts Contained in Service Kit

† O-ring used only in pumps manufactured prior to June 1993.

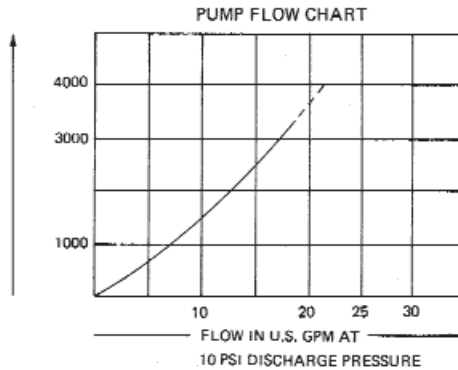

**xylem**  
Let's Solve Water

www.xylem-inc.com

**UK**  
**Xylem**  
Bingley Road, Hoddesdon  
Hertfordshire EN11 0BU  
Tel: +44 (0) 1992 450145  
Fax: +44 (0) 1992 467132

**USA**  
**Xylem**  
100 Cummings Center Drive  
Suite 535-N, Beverly, MA 01915  
Tel: +1 978 281-0440  
Fax: +1 978 283-2619

**ITALY**  
**Xylem**  
Via Tommaseo, 6  
20059 Vimercate, Milano  
Tel: +39 039 685 2323  
Fax: +39 039 666 307

**GERMANY**  
**Xylem**  
Oststrasse 28  
22844 Norderstedt  
Tel: +49-40-53 53 73-0  
Fax: +49-40-53 53 73-11

**JAPAN**  
**Xylem**  
3-21-10, Shin-Yokohama  
Kohoku-Ku, Yokohama, 222-0033  
Tel: +81-045-475-8906  
Fax: +81-045-477-1162

**Warranty:** All products of the company are sold, and all services of the company are offered subject to the company's warranty and terms of sale, copies of which will be furnished upon request. Details correct at time of printing. We reserve the right to change specifications without prior notice.