

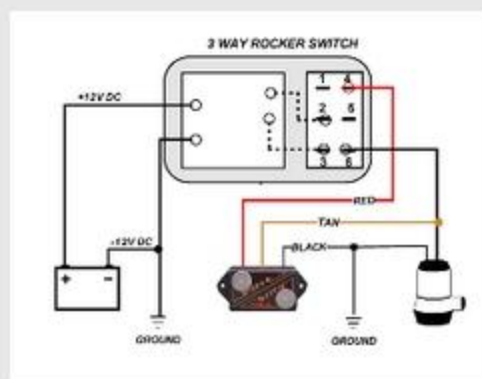

## Installation / Wiring Instructions

- Disconnect the battery.
- Select a mounting location for the monitor which is easy to see from the operating position.
- Check behind mounting panel for clearance (~3 inches), referring to diagram for dimensions.
- Use the enclosed template as a guide for cutting the hole. Cut the opening, following the instructions on the provided template. De-burr the hole and insert the e-PANEL to check for proper fit. DO NOT FORCE e-PANEL INTO HOLE.
- Follow the e-PANEL wiring schematic as illustrated in the diagram. The fuse is determined by the output load. Check with the manufacturer of the device to determine the correct size.
- From the Pump: connect the positive wire to the #6 switch terminal; connect the negative wire to ground.
- From the Water Watch: connect the RED wire to the #4 switch terminal; splice TAN wire into the positive connection from the pump to the #6 terminal on switch; connect the black wire to ground..
- From the e-PANEL: connect the positive terminal to the positive side of the battery; connect the negative terminal to ground. Check all wires for proper connection.
- Place e-PANEL in hole at the desired position. Tighten the e-PANEL against the mounting surface until flush and secure. DO NOT over tighten; it may crack housing or mounting dash.
- Reconnect the battery.



## Operating Instructions

- When power is applied, the alarm pulses three times with both buttons flashing indicating the panel and Intelli-mute and are active and working.
- Once an alert condition occurs, Intelli-mute activates the pulsing audible alarm and will continue to sound as long as an alarm condition is present.
- If the device connected to the ePanel runs for 2 minutes, Intelli-mute considers this an alarm condition and sounds the audible alarm.
- Pushing the mute silences the alarm but leaves the button flashing as a visual reminder.
- If after 5 minutes of being muted, the alarm condition still exists, Intelli-mute restarts the alarm cycle; i.e. if the device connected to the ePanel runs for more than 2 minutes, the audible alarm will sound again. This cycle continues until the alarm condition is resolved. Only when the alarm condition is resolved will Intelli-mute automatically reset the e-Panel.
- Whether muted or not, the panel is reset to the ready mode as if it had just been powered up.
- The TEST button allows a quick check of the e-Panel's audible output and visual flash mode buttons. Pressing the TEST button during an alarm mode will not affect the alarm condition.
- If the mute button is accidentally pressed and there is no alarm condition, Intelli-Mute waits for 5 minutes, checks for an alarm condition, turns off the mute feature and resets to its ready mode after 5 minutes.